

CS-3130

迫緊搭扣 Draw Latch (Spring Loaded Type)

SUS304



CS-112

迫緊搭扣 Draw Latch (Spring Loaded Type)

SUS304

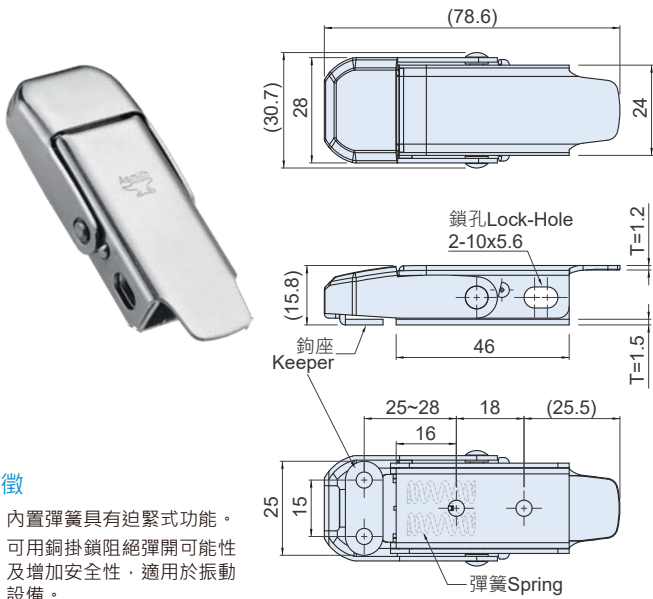

特徵

- 內置彈簧具有迫緊式功能。
- 可用銅掛鎖阻絕彈開可能性及增加安全性。適用於振動設備。

FEATURES

- Inner spring design with compression function.
- Standard Lock-hole can using with lock. Suitable for vibration equipment.

SPECIFICATION:

Unit:mm

產品編號 Item No.	材質 Material	表面處理 Finish	重量 Weight (g)
CS-3130	SUS304	震動亮面 Vibration ground	75

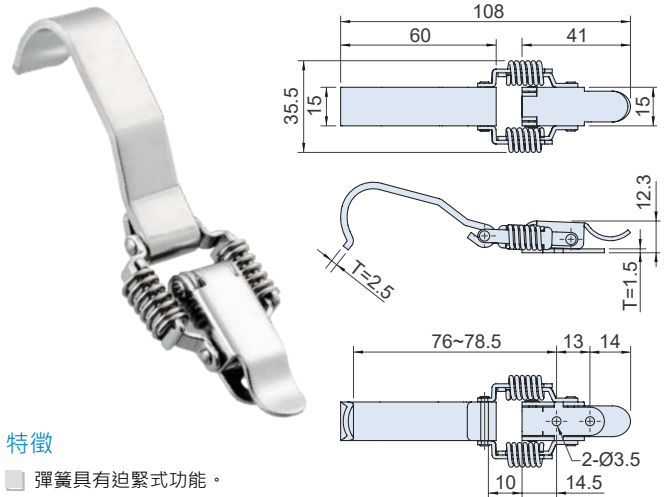

特徵

- 彈簧具有迫緊式功能。
- 耐腐蝕性、耐藥品性。
- 適合用於桶槽、振動設備。

FEATURES

- 2 springs provide strong and average compression force.
- Corrosion resistance.
- Suitable for barrels and vibration equipment.

SPECIFICATION:

Unit:mm

產品編號 Item No.	材質 Material	表面處理 Finish	重量 Weight (g)	引張荷重 Compression Force			
				1.5 mm	2 mm	3 mm	4 mm
CS-112	SUS304	震動亮面 Vibration ground	57	9 kgf	13 kgf	18 kgf	22 kgf

行程 (Spring compression : 1.5~4)

引張距離 \ 引張荷重 Extension Length \ Compression Force	
1.5 mm	2 mm
9 kgf	13 kgf
18 kgf	22 kgf

CS-1120
CT-1120

迫緊搭扣 Draw Latch (Spring Loaded Type)

SUS304



使用例
Example of application

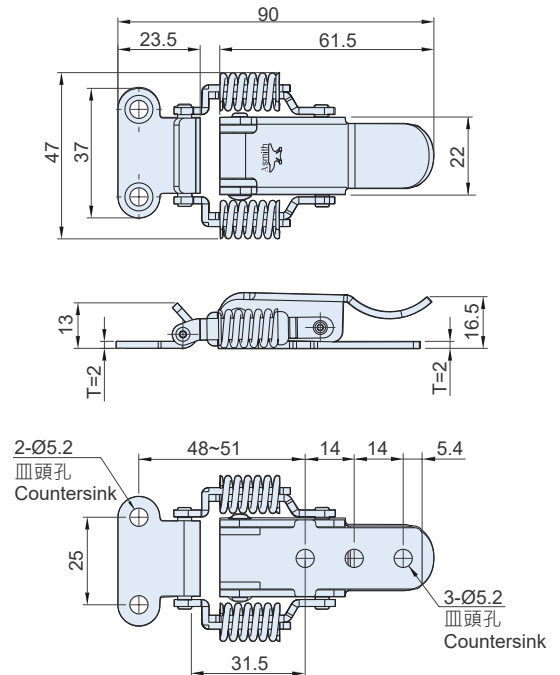
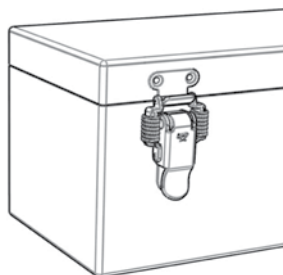

特徵

- 彈簧具有迫緊式功能。
- 可用銅掛鎖阻絕彈開可能性及增加安全性。適用於振動設備。

FEATURES

- Spring design with compression function.
- Standard Lock-hole can using with lock. Suitable for vibration equipment.

SPECIFICATION:

Unit:mm

產品編號 Item No.	材質 Material	表面處理 Finish	引張距離 \ 引張荷重 Extension Length \ Compression Force				重量 Weight (g)
			1 mm	2 mm	3 mm	4 mm	
CS-1120	SUS304	震動亮面 Vibration ground	22 kgf	27 kgf	32.5 kgf	38 kgf	88
CT-1120	SPCC	鍍鋅 Zinc Plated	28 kgf	36 kgf	41 kgf	47 kgf	88

行程 (Spring compression : 1~4)