

裝配示意圖 Installation

擋片軸心孔設計四點定位，可快速方便組裝完全不鬆轉。

Pawl is fixed by 4 positioning points and the grooved shaft-bolt, easy for assembly and adjustment.

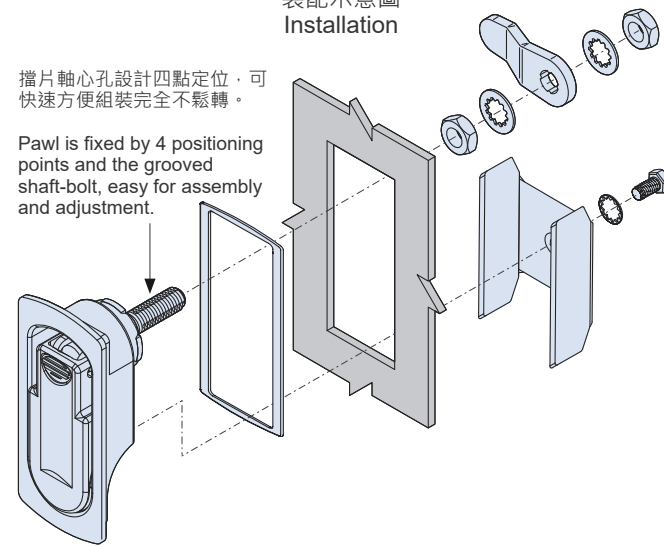

材質與表面處理

- 本體與握把：鋅合金、霧銘、黑色、亮銘。
- 軸心：鐵、鍍鋅。
- 擋片與固定架：鐵(SPHC)、鍍鋅。

特徵

- 專利設計：擋片軸心孔設計四點定位，可快速方便組裝。
- 現場裝配者只需旋轉一顆螺絲，即可快速安裝門鎖。
- 左、右、上、三方向兼用型。
- 開啟可後退 3mm 開閉迴轉順暢，關閉後門板可迫緊箱框不搖動。
- 耐熱、耐腐蝕性。
- 防塵、防水 (IP66)。

MATERIAL AND FINISH

- Body and Lever: Die-cast Zinc, Satin chrome plated or Black powder coated or Bright chrome plated.
- Shaft: Steel, Zinc plated.
- Pawl and Mounting Bracket: Steel (SPHC), Zinc plated.

FEATURES

- Patent: Pawl is fixed by 4 positioning points and the grooved shaft-bolt, easy for assembly and adjustment. Need only to slide the pawl through the shaft-groove to the correct position, more stable and accurate.
- Left, right and top opening.
- The pawl moved forward and reversed vertically 3mm while the compression latch is opened and closed.
- Resistance to heat, corrosion and dust.
- Dust-resistant and waterproof (IP66).

擋片型式 Pawl Type

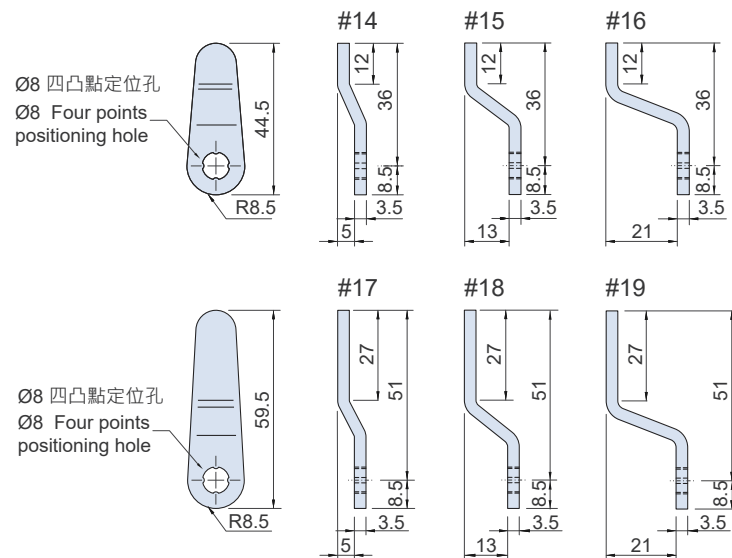

SPECIFICATION: Unit:mm

擋片型號 Pawl Type	材質 Material	表面處理 Finish	重量 Weight(g)
#14	鐵 SPHC	鍍鋅 Zinc plated	15.6
#15			17.6
#16			19.6
#17			20.6
#18			22.4
#19			24.2

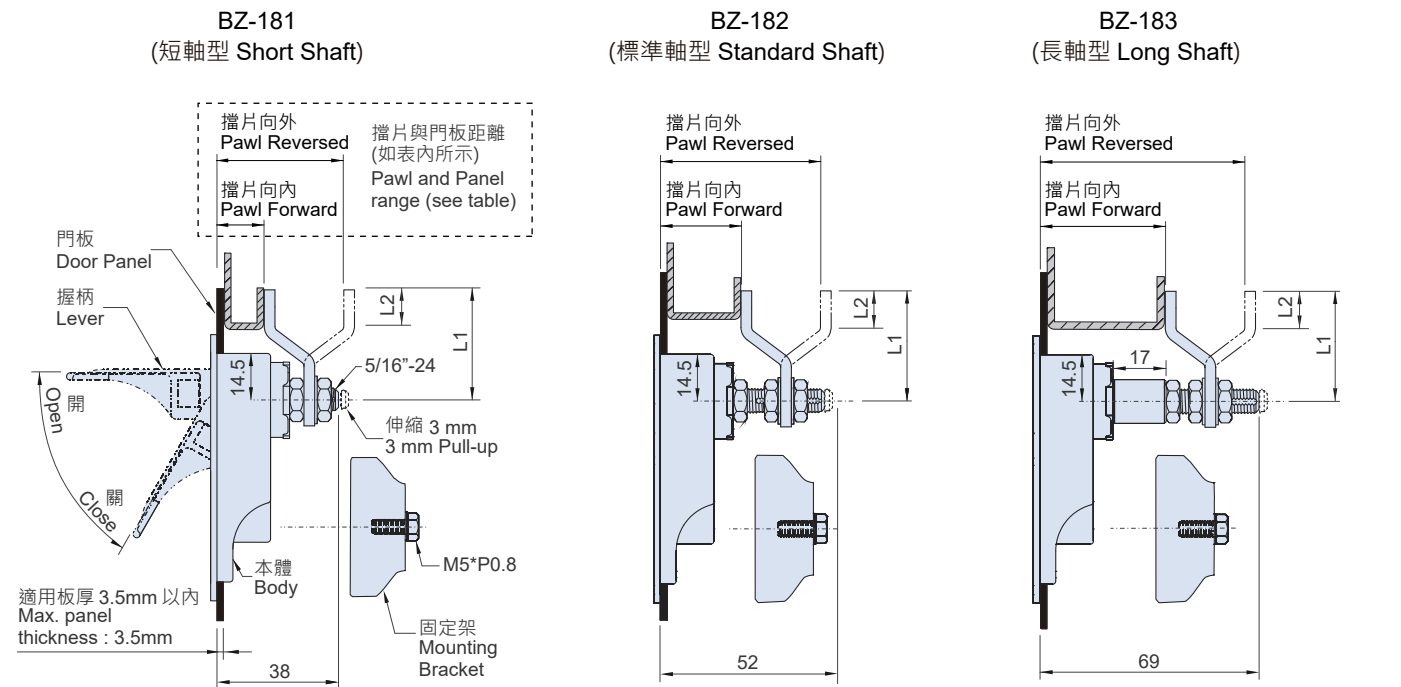

SPECIFICATION:

產品編號 Item No.			軸心型式 Shaft Type	擋片型式 Pawl Type	尺寸 Dimensions		擋片與門板距離 Pawl and Panel range		重量 Weight (g)
外觀霧銘 Satin chrome	外觀黑色 Black powder	外觀亮銘 Bright chrome			L1	L2	擋片向內 Pawl Forward	擋片向外 Pawl Reversed	
BZ-18114A(W)	BZ-18114B(W)	BZ-18114W(W)	短軸型 Short Shaft	#14	36	12	21	31	185
BZ-18115A(W)	BZ-18115B(W)	BZ-18115W(W)		#15			13	39	187
BZ-18116A(W)	BZ-18116B(W)	BZ-18116W(W)		#16			5	47	189
BZ-18117A(W)	BZ-18117B(W)	BZ-18117W(W)		#17			21	31	190
BZ-18118A(W)	BZ-18118B(W)	BZ-18118W(W)		#18			13	39	191
BZ-18119A(W)	BZ-18119B(W)	BZ-18119W(W)		#19			5	47	194
BZ-18214A(W)	BZ-18214B(W)	BZ-18214W(W)	標準軸型 Standard Shaft	#14	36	12	27~37	37~47	193
BZ-18215A(W)	BZ-18215B(W)	BZ-18215W(W)		#15			19~29	45~55	194
BZ-18216A(W)	BZ-18216B(W)	BZ-18216W(W)		#16			11~21	53~63	197
BZ-18217A(W)	BZ-18217B(W)	BZ-18217W(W)		#17			27~37	37~47	198
BZ-18218A(W)	BZ-18218B(W)	BZ-18218W(W)		#18			19~29	45~55	199
BZ-18219A(W)	BZ-18219B(W)	BZ-18219W(W)		#19			11~21	53~63	202
BZ-18314A(W)	BZ-18314B(W)	BZ-18314W(W)	長軸型 Long Shaft	#14	36	12	44~54	54~64	212
BZ-18315A(W)	BZ-18315B(W)	BZ-18315W(W)		#15			36~46	62~72	213
BZ-18316A(W)	BZ-18316B(W)	BZ-18316W(W)		#16			28~38	70~80	216
BZ-18317A(W)	BZ-18317B(W)	BZ-18317W(W)		#17			44~54	54~64	217
BZ-18318A(W)	BZ-18318B(W)	BZ-18318W(W)		#18			36~46	62~72	218
BZ-18319A(W)	BZ-18319B(W)	BZ-18319W(W)		#19			28~38	70~80	221