



BZ-0718C
BZ-0738C



BZ-0718
BZ-0738



BZ-0718B
BZ-0738B



【長軸型 Long-Shaft Type】

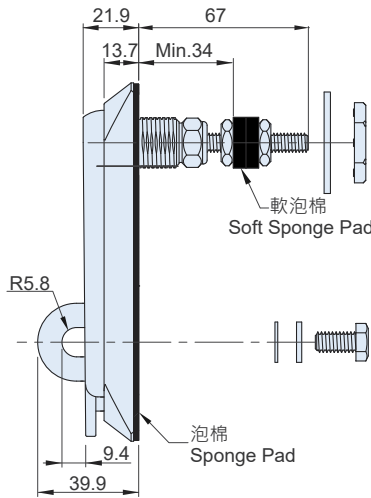

【短軸型 Short-Shaft Type】

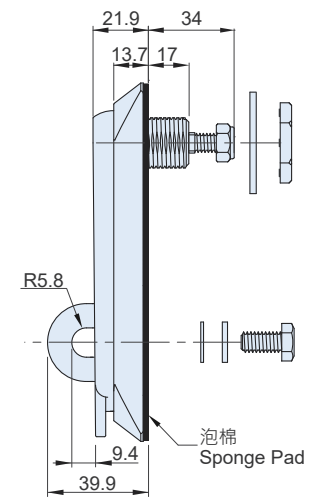

B 門鎖系列 Door Latches & Locks For Panels

安裝孔開孔尺寸
Opening Size

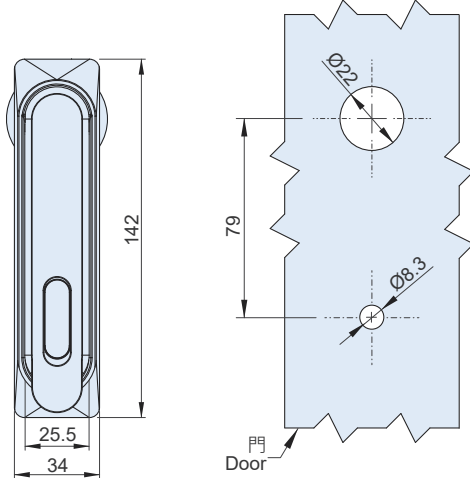

左開多點連桿裝配示意圖
Installation

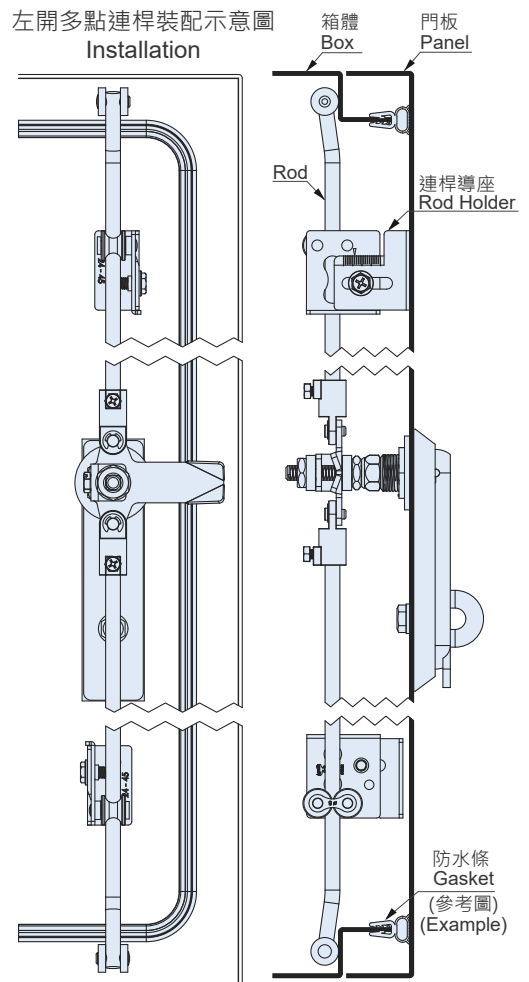

材質與表面處理

- 本體與掀把：鋅合金·電著黑·鍍鉻。
- 軸心：鐵·鍍鎳。

特徵

- 使用天地栓連桿讓門框不易搖動
- 適用板厚：5mm以內。
- 防塵·防水(IP66)。

MATERIAL AND FINISH

- Body and Lever: Die-cast Zinc, Chrome plated or Black coated.
- Shaft : Steel, Nickel plated.

FEATURES

- With pawl attaching rod system, the door frame will not shake.
- Max. door panel thickness: 5mm.
- Dust-resistant and waterproof (IP66).

SPECIFICATION:

Unit:mm

產品編號 Item No.			軸心型式 Shaft Type	重量 Weight (g)
鍍鉻 Chrome plated	本體黑色、掀把鍍鉻 Black Body, Chrome Lever	電著黑 Black coated		
BZ-0718C	BZ-0718	BZ-0718B	短軸型 Short Shaft	440.2
BZ-0738C	BZ-0738	BZ-0738B	長軸型 Long Shaft	476

備註：本產品不含檔片、天地栓連桿及連桿導座，請參考右頁選配。

Remark : The latch is without pawl, rod latch system, and rod holder. Please refer to the right page.

門鎖檔片 *Applicable Pawl*

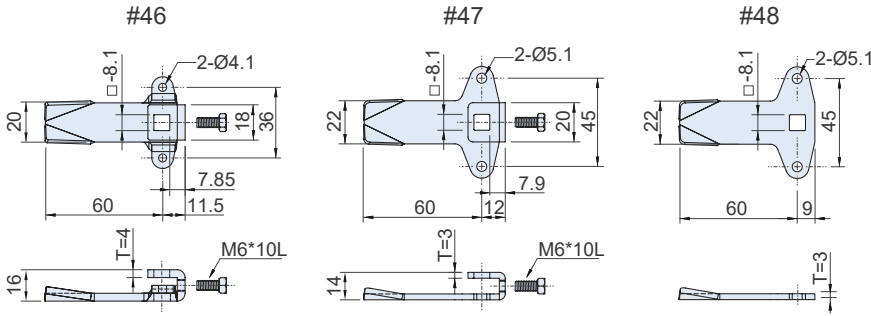

SPECIFICATION: Unit:mm

檔片型號 Pawl Type	材質 Material	表面處理 Finish	適用 Apply to	重量 Weight (g)
#46	鐵 SPHC	鍍鋅 Zinc plated	長軸型 Long Shaft	62
#47			短軸型 Short Shaft	57.6
#48				43.6

門鎖檔片附天地栓連桿 *Applicable Rod Latch System*

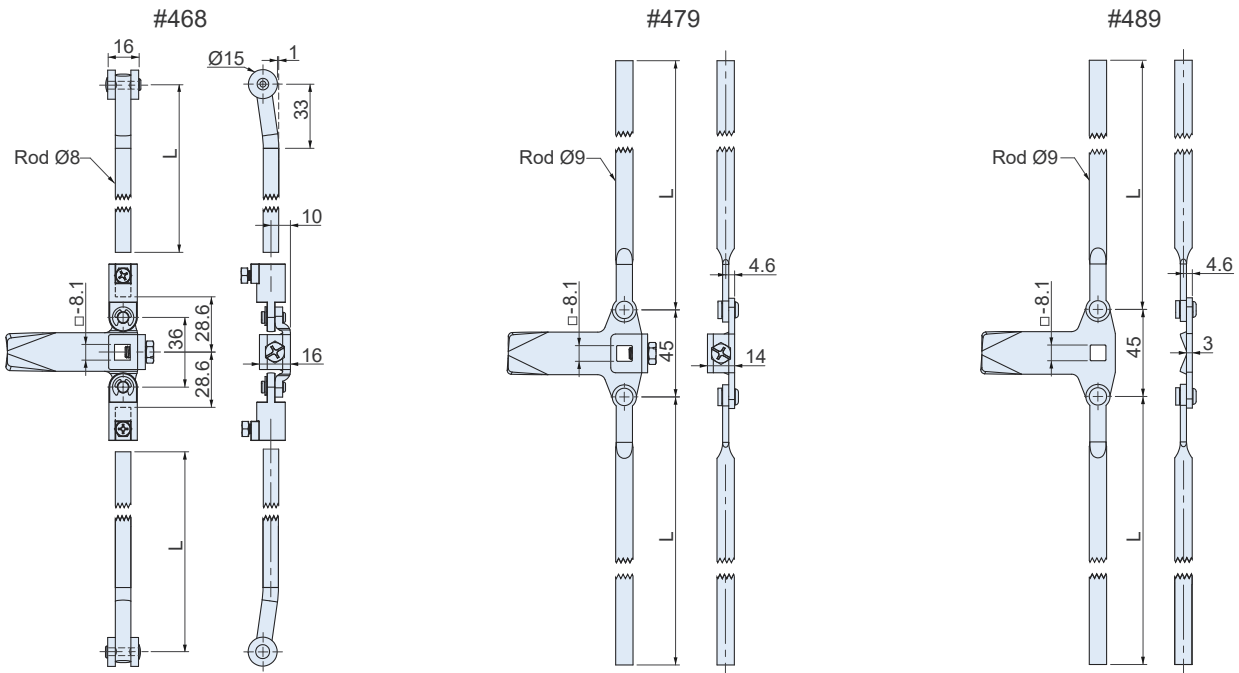

SPECIFICATION: Unit:mm

產品編號 Item No.	材質 Material	表面處理 Finish	L	重量 Weight (g)
#4680600	鐵 SPHC	鍍鋅 Zinc plated	600	587
#4681000			1000	907
#4681200			1200	1063

適用於長軸型門鎖 : BZ-0430
Apply to Long Shaft : BZ-0738 BZ-0423

SPECIFICATION: Unit:mm

產品編號 Item No.	材質 Material	表面處理 Finish	L	重量 Weight (g)
#4790620	鐵 SPHC	鍍鋅 Zinc plated	620	654
#4791020			1020	1074
#4791220			1220	1284

適用於長軸型門鎖 : BZ-0430
Apply to Long Shaft : BZ-0738 BZ-0423

SPECIFICATION: Unit:mm

產品編號 Item No.	材質 Material	表面處理 Finish	L	重量 Weight (g)
#4890620	鐵 SPHC	鍍鋅 Zinc plated	620	640
#4891020			1020	1060
#4891220			1220	1270

適用於短軸型門鎖 : BZ-0410
Apply to Short Shaft : BZ-0718

#538 Series 連桿導座 *Rod Holder*

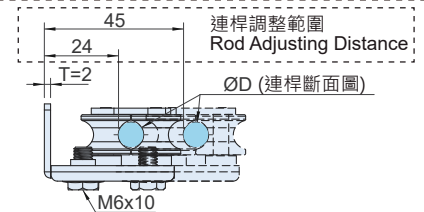
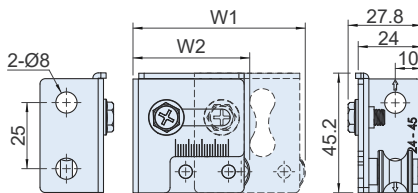

特徵

- 可調整距離及鬆緊度。
- 連桿上下滑動不產塵。

FEATURES

- For adjusting the tightness and length of the rod latch system.
- Non-dust from operating the rod latch system.

SPECIFICATION: Unit:mm

產品編號 Item No.	材質 / 表面處理 Material / Finish	W1	W2	D	適用於 Apply to	重量 Weight (g)
#5382	本體Body : 鐵 Steel (PO) 鍍鋅 Zinc plated	65.1	44.1	Ø8	#468	78.3
#5383	滾輪Wheel : POM	66.1	45.1	Ø9	#479 #489	