

迷你數位扭力扳手系列

Mini Digital Torque Wrench Series

使用者手冊
User Manual

中文

P. 2

產品概述	P. 2
產品特色	P. 3
產品技術規格	P. 8
使用前注意事項	P. 9
產品功能	P. 10
保養及注意事項	P. 18

English

P. 26

Product Overview	P. 26
Product Features	P. 27
Technical Specifications	P. 32
Precautions before Use	P. 33
Product Functions	P. 34
Maintenance and Precautions	P. 43

親愛的客戶：

我們非常感謝您購買數位扭力扳手與對本產品的支持。為了讓您完全享有產品的優點，請在調整任何設定前先閱讀下列指示，並保存本手冊，以供日後參照。

1. 產品概述

由於扭力量測校驗需要做嚴格的認證，儀器本身包括溫度、精確度與解析度，更需要具有抗干擾能力 (ESD 與 EMI)，這些除了周邊零件的特性需要達到規格要求之外，更需要量測晶片的規格能符合要求。因此，如果能夠簡化周邊的被動元件，這時又能夠準確的量測出扭力值，不單是能夠節省成本，相對可以提高維修及組裝品質，更可以降低受用物件之損壞率。

2. 產品特色

簡易多功能操作，具有防震、預設扭力值、單位切換、模式切換、記憶儲存、數字遞增 & 遞減、省電模式、LED 燈號、響聲警示、震動警示等。

2.1 數位扭力值顯示

2.2 LCD 背光顯示

2.3 順時針及逆時針皆可操作

扭力精度：CW \pm 3% (順時針)

CCW \pm 4% (逆時針)

2.4 可儲存 30 組設定值

2.5 省電模式 (2 分鐘進入省電模式)

2.6 具有蜂鳴、震動及 LED 燈號警示功能

2.7 低電壓偵測 (提醒使用者電池壽命)

2.8 四種扭力單位，可供選擇切換

Nm、Kg.cm、lb-ft、lb-in

(扭力起子單位：cN-m、Kg-cm、lb-in)

2.9 可使用一般碳鋅電池及鹼性電池

各部件功能及名稱

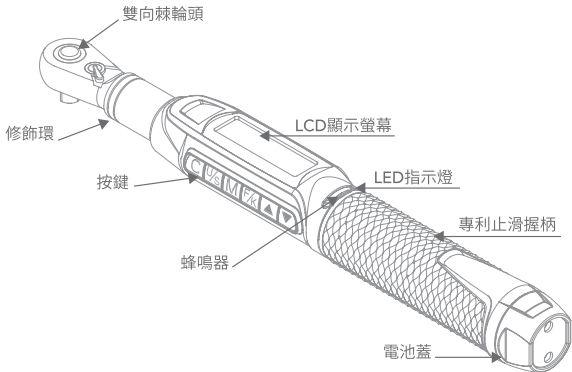

面板

- ① 電源及清除按鍵
- ② 單位選擇按鍵
- ③ 記憶選擇按鍵
- ④ 模式選擇
- ⑤ 向上按鍵
- ⑥ 向下按鍵
- ⑦ 扭力值顯示
- ⑧ F/K (追隨 / 峰值)
- ⑨ 單位顯示

(cNm 扭力起子系列)

- ⑩ 電池壽命顯示
- ⑪ 百分比顯示
- ⑫ 記憶組數顯示

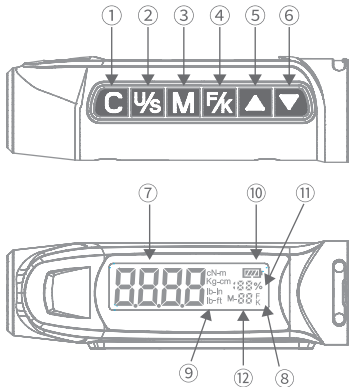

扳手種類

- Ⓐ Bits 插槽
- Ⓑ 雙向棘輪頭
- Ⓒ 釋放鈕
- Ⓓ 正反轉方向撥片
- Ⓔ 棘輪扭力方頭
- Ⓕ 頭部拆換卡榫

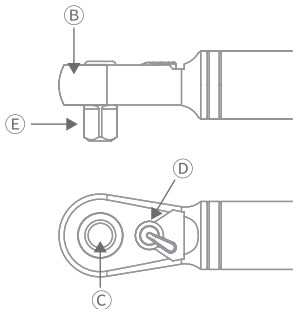
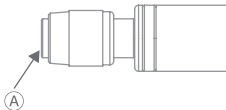

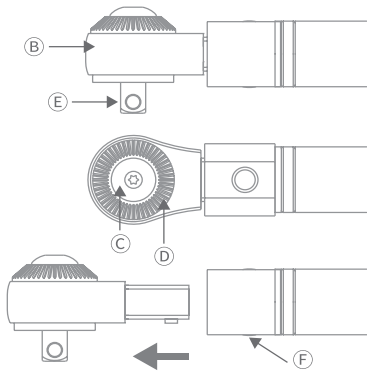
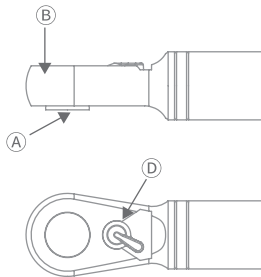

※ 更換頭部時 請關閉扭力扳手控制器電源。

3. 產品技術規格

扭力精度*	CW : $\pm 3\%$ CCW : $\pm 4\%$
LED 警示燈	2 LED (1 綠 + 1 紅)
震動警示	有 (達設定值 90% 開始動作)
操作模式	Track(F) / Peak hold(K)
單位選擇	Nm、kgf.cm、lbf.in、lbf.ft 扭力起子 (cNm)
電池壽命 (連續操作)	110 hrs.
電池壽命 (待機模式)	1 year
濕度	Up to 90% non-condensing

設定值 儲存容量	30 組
操作溫度	-10°C ~ 60°C
儲存溫度	-20°C ~ 70°C
摔落測試	1m
振動測試	10 G
壽命測試	10000 cycle
環境測試	Pass
電磁相容測試	Pass

※ * 精度說明：依據 ISO6789：2003 扭力精度在最大操作值的 20% ~ 100%

4. 使用前注意事項

4.1 置入電池

4.1.1 打開電池蓋。

4.1.2 置入電池，
請注意正負極方向。

4.1.3 裝上電池蓋。

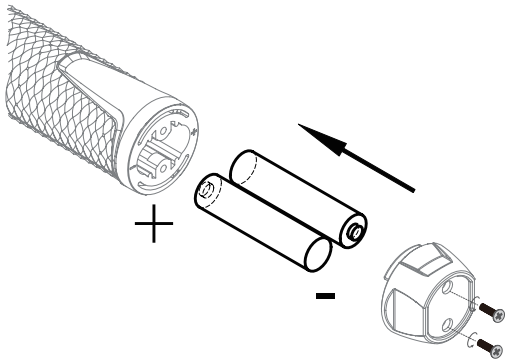

4.2 低電壓通知

如果系統偵測電池電壓低於 2.3V 時，螢幕右上角會出現電池符號，並在數秒之後關機。



5. 產品功能

共有六顆按鍵，表示符號分別如下：



按鍵名稱	按鍵功能說明
C	開關機及歸零
U/S	單位選擇
M	記憶選擇
F/K	設定值模式選擇
▲	數字遞增選擇 (UP)
▼	數字遞減選擇 (DOWN)

5.1 開關機及歸零

開機：按下 C 鍵開機，背光亮 LCD 文字全閃，由左至右顯示 0000 後，進入操作模式。第一次使用產品時，進入操作模式時，顯示該產品最小操作值，單位預設為 Nm，(扭力起子單位預設為 cNm) 顯示記憶為第一組，模式為追隨模式 F，百分比位置顯示 0%，電池刻度依當時偵測到的電壓值顯示該電池刻度 (30 組設定值記憶、預設值皆相同)。

關機：長按 C 鍵 3 秒關機。

歸零：開機狀態下按下 C 鍵歸零。

5.2 單位切換 / 選擇

國際標準公制為 Nm，公制為 Kg.cm，英制為 lb-in 及 lb-ft 等 4 種，每按下一次 U/S 鍵單位便切換，順序為 Nm、Kg.cm、lb-in、lb-ft；預設單位為 Nm。

扭力起子的國際標準公制為 cN-m，公制為 Kg-cm，英制為 lb-in 等 3 種，每按下一次 U/S 鍵單位便切換，順序為 cN-m、Kg-cm、lb-in; 預設單位為 cN-m。

► 扭力單位換算對照表：

	lb-in	lb-ft	cNm	Nm	Kg.cm
1 lb-in	1	0.083	11.3	0.113	1.152
1 lb-ft	12	1	135.6	1.356	13.83
1 cNm	11.3	0.007	1	0.01	0.102
1 Nm	8.851	0.737	100	1	10.2
1 kg.cm	0.868	0.072	9.807	0.098	1

5.3 設定值記憶功能

所有的設定值記憶組別，第一次預設值皆為範圍最小值，記憶選擇方式，按下 M 鍵後 M-01 最右邊數值開始閃爍，即進入選擇模式，使用▲ (UP) / ▼ (DOWN) 選擇記憶組別，亦可持續按住連續遞增 / 減，選擇完畢後再按 M 鍵確認，停止閃爍即離開選擇模式。

5.4 追隨模式 F/ 保持模式 K

► 追隨模式：(第一次開機預設為追隨模式)

數值選定後 (假設選 50Nm)，扳手施力時數值由 0000 往上遞增，當施力者施力，所顯示的值會依施力者的力度不同產生改變，用力就遞增，放鬆遞減，拿起或完全放鬆，顯示值將跳回 50Nm。

► 保持模式：

數值選定後 (假設選 50Nm)，扳手施力時數值由 0000 往上遞增，當施力者施力，所顯示的值會依施力者的力度不同產生改變，完全停止施力後，顯示值為最後的扭力值，閃爍 10 秒之後 (此時任何動作及按鈕皆無效)，自動回到設選數值，或按 C 鍵可以回到設選數值，亦可直接施力後，重新由 0000 往上遞增量測扭力值。

5.5 量測範圍數值選擇

在無施力量測或是設定值記憶選擇之下，數值皆可選擇，任何模式下完成施力測試後，皆會回到顯示選取的數值。

5.6 ▲ (UP) / ▼ (DOWN) 選擇

▲ (UP) 鍵時，按一下由最右邊數值開始遞增，持續按住連續遞增；▼ (DOWN) 鍵，按一下由最右邊數值開始遞減，持續按住連續遞減。

5.7 LED 燈 & 蜂鳴器

LED 燈在每個按鍵按下時綠燈亮且皆有嗶聲。

▶ 追隨模式下，LED 燈兩顆分別為綠色、紅色，假設當設定的扭力值為 20Nm 時，使用者開始施力，數值由 0000 開始變化數值到達設定值的 80%，此時綠燈亮起開始閃爍，蜂鳴器開始發生聲音，當施力者扭力越接近該設定數值時，綠燈閃爍越快，蜂鳴聲越快，當數值到達設定值 100% 時，綠燈恆亮，蜂鳴聲保持聲響，超過該設定值時 (101%)，紅燈亮起，蜂鳴聲保持聲響，施力放鬆則遞減。

▶ 保持模式下，同追隨模式，但施力者完全停止施力後，LED 燈及蜂鳴聲停止。

5.8 震動警示功能

假設當設定的扭力值為 20N-m 時，使用者開始施力，數值由 0000 開始變化數值到達設定值 90%，此時震動警示開啟，施力放鬆低於設定值 90% 則關閉震動。

5.9 LCD 百分比 % 數顯示

一般顯示為 0%

▶ 追隨模式下，使用者設定值為 50Nm，開始施力由 0Nm 至 25Nm 時，顯示為 50%，以此類推，放鬆後扭力值遞減，直到完全放鬆，跳回扭力設定畫面。

▶ 保持模式下，效果同追隨模式，但完全停止施力後，顯示值為最後的扭力值 % 數，最高顯示 100%。

5.10 低電壓顯示

LCD 電池顯示有四個刻度，大於等於 3V 時刻度全滿，小於 2.8V 時刻度剩 3 格，小於 2.6V 時刻度剩下 2 格，小於 2.4V 時剩下一格，小於 2.3V 時任何功能皆停止，LCD 電池閃爍 5 秒後關機。

5.11 重置記憶功能

按住 C 鍵 + ▼ (DOWN) 鍵，五秒後，所有記憶數值將回到出廠預設值。



5.12 背光開關

按下 C 鍵 + ▲ (UP) 鍵，背光 ON/OFF，預設為 ON。



5.13 歸零重置

使用產品前都要按 C 鍵，可確保精準數據。勿在施力狀態下按下 C 鍵，將會產生錯誤的初始值。

5.14 省電裝置

無操作時，2 分鐘後進入省電模式，按 C 鍵喚醒。

5.14 過載警示

開機或歸零時若畫面持續出現 110%，表示施力超過最大標準值 110%，可能會造成本品損壞喪失精準度。

正常



過載



6. 保養及注意事項



注意警語



為了維持良好精度，建議大約每年需重新校正一次。

- 6.1 請勿使用有機溶劑清潔本品，如酒精或是油漆稀釋劑。
- 6.2 請勿將本品靠近磁性物體。
- 6.3 請勿重壓 LCD 螢幕。
- 6.4 請勿將本品當作敲擊工具使用。
- 6.5 請勿使用榔頭敲擊本品。
- 6.6 使用超過扭力最大標準值可能會造成本品損壞喪失精準度。(超過最大扭力值 110%)
- 6.7 請勿在靠近水的地方使用本品。
- 6.8 若不慎弄溼，請立即用乾布擦拭乾淨。
- 6.9 請勿將本品放置在高溫、高濕或是太陽直射之處。
- 6.10 請勿將本品暴露充滿灰塵或風沙的環境下，如此可能造成裝置嚴重損壞。
- 6.11 請勿將本品劇烈搖晃或將扳手重摔落地上。
- 6.12 如果長時間不使用本品時，請將電池取出。
- 6.13 請將使用完之電池丟棄在指定回收處。請勿將電池至入火中。

- 6.14 使用本品前請詳閱操作手冊並依照手冊流程進行操作。
- 6.15 關機狀態下禁止使用。
- 6.16 請勿將手把外加延長桿使用。例如：鐵管或塑料管。
- 6.17 在施加扭力時，請勿按任何按鍵。
- 6.18 請勿在通電的物品上使用本品。

※ 使用方法

■ 數位扭力扳手

扳手握柄使用示意圖

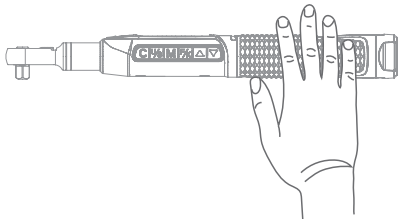

■ 數位扭力起子

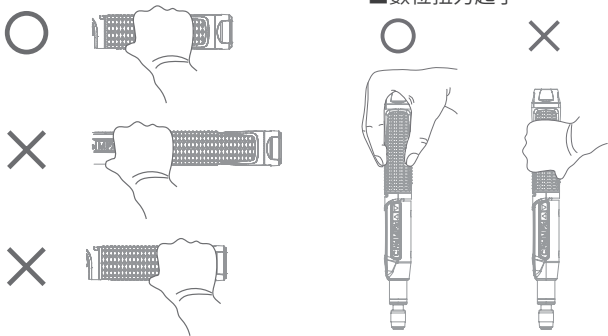

P.S: 完成開機程序前 (請參照 5.1 說明), 請勿施力於扭力扳手 (起子)。

■電池使用相關訊息

1. 若長時間不使用本品，請將電池取下。
2. 若使用於長途旅程或是位於寒冷地區，請多準備備用電池。
3. 請勿將新與舊的電池混合使用。
4. 汗水、油污都會使電池加速老化，為避免此情形發生，請於裝入電池前將電池擦拭乾淨。
5. 請依照當法規回收舊電池，請勿將電池丟入火中。
6. 本品可使用一般碳鋅電池及鹼性電池。
7. 若螢幕畫面無法顯示，請檢查電池是否沒電，必要時請加以更換。

※ 保固說明

■產品保固期限標準

本公司產品透過更完善的保固要求來達到延長產品使用壽命的目的，進而提升消費者使用意願，並提供一年電子零件有限保固與維修服務。

■ 保固標籤及序號辨識說明

請洽代理商或當地經銷商。



■ 保固範圍

於保固期間內，產品因材料或製造上確有瑕疵，致影響產品功能，本公司將以負責維修或以同型號之良品更換之。

■ 保固除外條款

雖然仍然在保固期限內，若屬於下列任一情況者，則產品不在保固範圍內，消費者須負擔全部維修費用或材料費，收費標準依其代理商或當地經銷商其所指定之維修服務據點規定。

1. 無法證明產品之保固期限或超過產品之保固期限。
2. 產品序號載明不相符者。產品序號不清楚，或被更改、撕毀者。
3. 因消費者未按使用手冊或說明書規定，使用不當而毀損者，產品之毀損係受不可抗力（天災、水災、火災、地震、雷擊、颱風、蟲害等），人為破壞（刮傷、摔傷、卡榫斷裂、敲打、破裂、重擊等），人為疏失（遺失、液體入侵、未妥善保管等）或其他非正常因素所致者。
4. 因正常使用時，所造成產品外殼或不需拆解而可接觸部分上之刮傷、磨損。
5. 客戶擅自或使第三人安裝、添附、擴充、修改、修復非本公司授權或認可之零件所致之毀壞。
6. 新品不良換貨服務範圍：
 - 無法正常開啟電源時
 - 按鍵無法操作調整時
 - 無法正常顯示畫面時
 - 控制功能無效時不符合上述新品換貨原則者，則以維修方式處理。

7. 更換零件時，本公司提供規格相同或更佳之良品；若非雙方另有書面約定，維修更換後之不良零件歸本公司所有。
8. 外觀、外殼及裝飾性的零組件機構受損不包括在本有效保證條款內，將無法提供免費維修服務。
9. 非本公司授權之經銷管道所買之產品。
10. 消費者自行運送過程中所導致之損害。
11. 因機器外之其他產品（設備）所引起之故障。通知個別消費者。

■其他建議事項

請確認您的產品規格及配件。

■權利保留

本公司保留變更條款內容之權利，日後本條款如有任何變更，本公司將公告之，不另通知個別消費者。

Dear customer,

We appreciate your purchase of our digital torque wrench. To learn more about the advantages of this product, kindly read the instructions carefully before you start to adjust any settings. Please keep this manual for your reference at all times.

1. Product Overview

As torque measurement and calibration requires strict certification, torque instruments must possess good temperature, precision, and resolution capabilities, and also have the ability to correct disturbances (ESD and EMI). While the characteristics of peripheral components must meet specification requirements, measurement chip specifications must also meet requirements. For this reason, the simplification of peripheral passive elements allows an instrument to accurately measure torque values and angle degree, which will not only save cost but also improve maintenance and assembly quality, as well as reduce the probability of damage to used objects.

2. Product Features

This product is easy to operate with multiple functions, including shockproof, preset torque value, unit switching, mode switching, memory storage, number increment and decrement, power-saving mode, LED light, sound and vibration warning.

2.1 Digital torque value display.

2.2 LCD backlight display.

2.3 Operable for both clockwise and counterclockwise directions.

Accuracy: CW \pm 3% (clockwise) CCW \pm 4% (counterclockwise)

2.4 Able to save up to 30 sets of set values.

2.5 Power saving mode (enters power-saving mode in 2 minutes).

2.6 Equipped with buzzer, vibration and LED light warning functions.

2.7 Low voltage detection (reminds user of battery life).

2.8 Four torque units available for switching : Nm/kgf.cm/lbf.in/lbf.ft

(Torque screwdriver units: cNm/kgf.cm/lbf.in)

2.9 Both zinc-carbon battery and alkaline battery can be used on this instrument.

Function and Name of All Parts

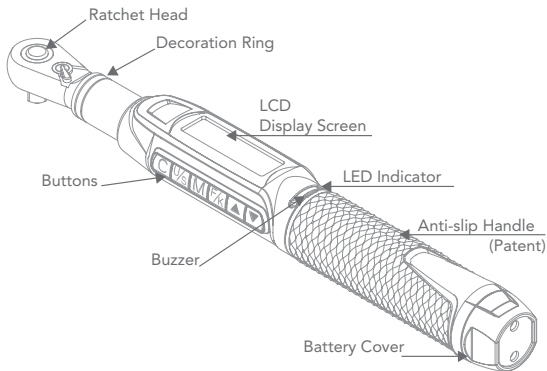

Panel Function

- ① Power & Reset button
- ② Unit switch
- ③ Memory button
- ④ Mode switch
- ⑤ Up button
- ⑥ Down button
- ⑦ Torque value display
- ⑧ F/K (Track/Peak)
- ⑨ Unit display
(cNm on Torque Screwdriver Series)
- ⑩ Battery life display
- ⑪ Percentage display
- ⑫ Memory group display

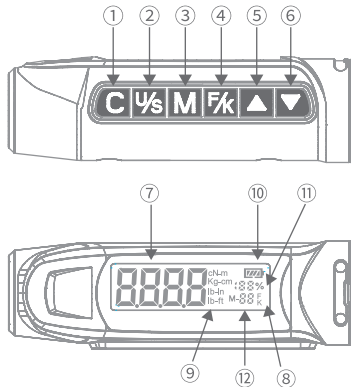

Wrench Type

- Ⓐ Bits insert
- Ⓑ Ratchet head
- Ⓒ Realease button
- Ⓓ Forward and reverse paddle
- Ⓔ Ratchet torque square head
- Ⓕ Changeable head joint

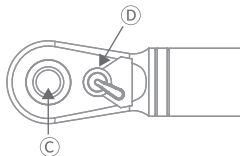
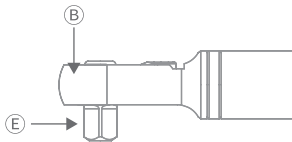
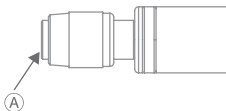

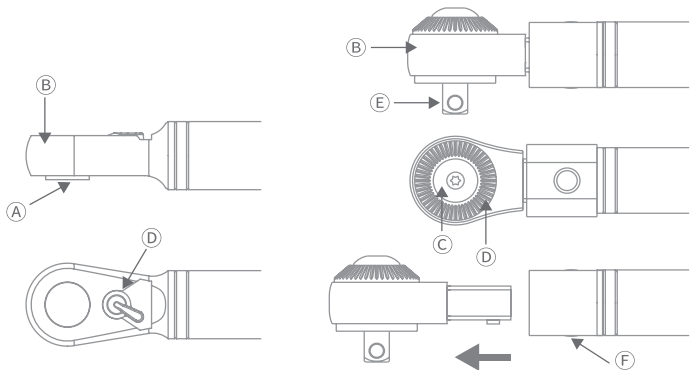

※ Power Off before exchanging the torque head.

3. Technical Specifications

Torque Accuracy*	CW : $\pm 3\%$ CCW : $\pm 4\%$
LED Indicator	2 LED(1 Green + 1 Red)
Vibration warning	Yes (activate when set value reaches 90%)
Operation Modes	Track(F) / Peak hold(K)
Unit	Nm 、 kgf.cm 、 lbf.in 、 lbf.ft Torque Screwdriver (cNm)
Battery life (Continuous operation)	110 hrs.
Battery life (Standby Mode)	1 year
Humidity	Up to 90% non-condensing

Memory Capacity	30 Sets
Operating Temperature	-10°C ~ 60°C
Storage Temperature	-20°C ~ 70°C
Drop Test	1m
Vibration Test	10 G
Life Test	10000 cycle
Environmental test	Pass
EMC Test	Pass

※ *Torque Accuracy: According to ISO6789:2003, a specified measuring range from 20% to 100% of the maximum torque value of the respective tool.

4. Precautions before Use

4.1 Battery Install

4.1.1 Open the battery cover.

4.1.2 Install the batteries.

Notice the direction of the polarity

4.1.3 Close the battery cover.

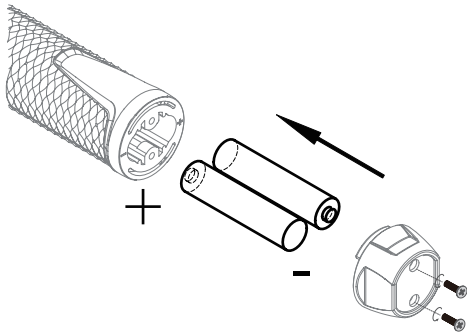

4.2 Low Voltage Notification

If the system detects a voltage level of less than 2.3V, a battery icon will appear at the upper right corner of the screen, and the system will shut down a few seconds later.



5. Product Functions

The function panel have 6 buttons, the function is as follow:



Button	Function
C	Power & Reset
U/S	Unit Selection
M	Memory Selection
F/K	Mode Switch
▲	Number Increasing (UP)
▼	Number Decreasing(DOWN)

5.1 Power and Reset

Power ON Press the C button to turn on the wrench. Next, the backlight comes up, and all the text on the LCD flashes. After displaying 0000 from left to right, the wrench enters into operation mode.

When using the wrench in operation mode for the first time, the minimum operation value is displayed, and the unit is preset as Nm (the torque screwdriver is preset as cNm). Besides, memory for the first set is displayed, while the product is also set to Mode Track (F), and the percentage is displayed as 0%. The battery scale displays the battery level according to the voltage level detected at that time (the memory for 30 sets of set values and the preset values are the same).

Turn Off : Press C key and hold 3 seconds to switch off.

Clear : Press C key to reset (when device turned on).

5.2 Unit Selection

Press the U/S button to select, the unit will be set in the following order: Nm, Kg.cm, lb-in and lb-ft. The preset unit is Nm.

Torque screwdriver unit will be set in the following order: cNm, Kg.cm, lb-in lb-ft.
The preset unit is cNm.

► Torque unit conversion table

	lb-in	lb-ft	cNm	Nm	Kg.cm
1 lb-in	1	0.083	11.3	0.113	1.152
1 lb-ft	12	1	135.6	1.356	13.83
1 cNm	11.3	0.007	1	0.01	0.102
1 Nm	8.851	0.737	100	1	10.2
1 kg.cm	0.868	0.072	9.807	0.098	1

5.3 Set Value Memory

For the memory of each set of set values, the initial preset value is the minimum value in the range. To choose a memory, press the M button, the rightmost value the of M-01 starts to flash and the wrench enters into selection mode. Press the ▲ (UP) or ▼ (DOWN) button to choose the memory for a particular set of set values. You can press these buttons to continuously increase or decrease the set number. After selecting, press the M button to confirm the selection. When the value stops flashing, it indicates that the wrench has exited selection mode.

5.4 (F) Mode/ (K) Mode

▶ **(F) Mode:** (preset as tracking mode at time of first use)

After setting a value (assuming the value is 50Nm), the force applied by the wrench will gradually increase from 0000. When force is applied, the displayed value will change as the user applies different amounts of force; the reading will increase as force increases, and decrease as force decreases. The reading will jump to 50Nm when the user relaxes his grip and lets up.

▶ **(K) Mode:**

After the value is selected (assuming 50Nm is selected), when the wrench is applied with force, the value increases from 0000 upwards. When the force is applied by the force, the displayed value will change according to the force of the applying force, and after the force is completely stopped, the value is displayed. For the final torque value, flashes for 10 seconds. After 10 seconds, continue to apply the torque value will automatically accumulate (at this time, any action and button are invalid). After 10 seconds, no force will continue to return to the selected value, or press C can be returned to the selected value.

5.5 Measurement Range Selection

Values can be freely selected as long as force is not being measured or memory selection has not been performed. After completing torque measurement in either mode, the selected value can be displayed.

5.6 ▲ (UP) / ▼ (DOWN) Selection

Pressing the ▲ (up) key once will cause the value on the far right to increase by one; pressing the key continuously will cause the value to increase continuously. Pressing the ▼ (down) key once will cause the value on the far right to decrease by one.

5.7 LCD Backlights Warning & Buzzers

(There will be a beep each time a key is pressed.)

► In Track mode, the two LED light will function as green and red. Assume that the torque value is set at 20Nm. When the user starts applying force to the wrench, the value changes from 0000. When the force reaches 80% of the set value, the green light starts to flash, and the buzzer starts to sound. When the torque value approaches the set value, the green light flashes faster and the buzzer sounds faster. When the force reaches 100% of the set value, the green light comes up permanently, and the buzzer sounds continuously. When the force exceeded the set value(101%) , the red light comes up, and the buzzer continues to sound. The value decreases when the force applied to the wrench is decreased.

► The Peak Mode is similar to the Track mode. However, in Peak Mode, the LED light and the buzzer stops after force applied to the wrench is completely removed.

5.8 Vibration Warning Function

Assume that the set torque value is 20Nm. When the user starts to apply force to the wrench, the value changes from 0000. When the value reaches 90% of the set value, vibration warning is activated. When the force applied decreased to less than 90% of the set value, vibration warning turned off

5.9 LCD Percentage Display

The display generally shows 0%.

- ▶ In Track mode, assume that the user's set value is 50Nm. When force applied as the torque value increase from 0Nm to 25Nm, the screen shows 50%, and so on. When force decreased, the torque value decreases. When force applied is stopped, the display will return to the torque setting screen.
- ▶ The effects in Peak Mode are similar to what in the Track mode. However, after force applied is stopped, the display shows the percentage of the last torque value, with the highest percentage being 100%.

5.10 Low Voltage Display

There are four bars on the LCD battery display. All four bars are shown when the voltage level exceeds 3V, whereas three bars are shown when the voltage level is less than 2.8V. When the battery level is less than 2.6V, only 2 bars are left on the battery display. When the voltage level is less than 2.3V, all functions stop. The wrench will shut down after the LCD battery icon flashes for 5 seconds.

5.11 Reset Memory Function

Press and hold the C button + ▼ (Down) button. 5 seconds later, all the memory values are reset to factory default values.



5.11 Backlight Switch

Press the C button + ▲ (up) button to preset the backlight ON/OFF switch to ON.



5.13 Resetting

Before using this product, press the C button to ensure accurate data. Do not press the C button when applying force to the product as it may generate the wrong initial values.

5.14 Power Saving Mode

When the wrench is not in use, it will enter power saving mode after 2 minutes. Press the C button to wake up the wrench.

5.15 Overload Warning

If the screen continuously shows 110% when the wrench is turned on or returned to zero, it indicates that the torque applied exceeds the maximum standard value of 110%. It may result in damage to this product and cause this product to lose its accuracy.

Normal



Overload



6. Maintenance and Precautions



NOTE THE WARNINGS



In order to maintain good accuracy, we recommend that you perform calibration around once each year.

- 6.1 Do not utilize any organic solvents to clean the product, such as: alcohol or paint thinner etc.
- 6.2 Do not place the product nearby any magnetic products.
- 6.3 Do not exert heavy force or pressure on the LCD screen.
- 6.4 Do not use the products as striking tools.
- 6.5 Do not hit the products by using hammer or other tools.
- 6.6 Exceeding the largest standard torque value may result in the products' damage or accuracy error(110%).
- 6.7 Do not use near or place in water.
- 6.8 Please wipe the product clean with a dry cloth, if the product is wet.
- 6.9 Do not place the product in the high temperature and damp environment or do not expose the product to sunlight.

ENGLISH

- 6.10 Do not place the product in the full dust or sand environment.
- 6.11 Do not violently shake or drop the product.
- 6.12 Please take out the batteries if the product is not used a long period of time.
- 6.13 Do not throw the batteries into fire, and the batteries have to be recycled.
- 6.14 Please read carefully the operating manual, and then follow the guides of the manual, before using the digital torque adapter.
- 6.15 Shutdown state is prohibited to use.
- 6.16 Do not use the additional tools to extend the length of the handle, such as: iron or plastic pipe.
- 6.17 Do not touch any button when torque is exerted.
- 6.18 Do not use this product on set up an electric items.

※ Method of Use

■ Digital Torque Adapter

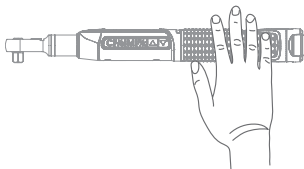

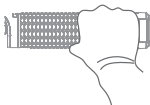
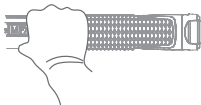
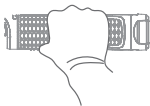

■ Digital Torque Screwdriver

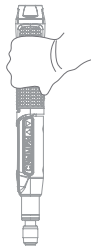
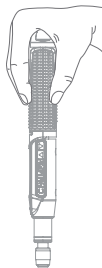

P.S: Before completing the procedure for turning on this product (refer to Section 5.1), do not apply force to the torque wrench.

■ Information Related to Battery Use

1. Remove the batteries if this product is not in use for a long period of time.
2. Prepare spare batteries if this product is to be used on long journeys or in cold areas.
3. Do not use this product by mixing both new and old batteries.
4. Sweat and oil stain will speed up battery aging. To prevent this phenomenon, wipe the batteries clean before inserting them into this product.
5. Recycle old batteries according to local regulations. Do not throw batteries into fire.
6. Both ordinary zinc-carbon batteries and alkaline batteries can be used in this product.
7. If the screen cannot be displayed, check whether the batteries are dead. Replace the batteries when necessary.

✂Warranty

■ Product Warranty Period

Our company achieves the purpose of extending the useful life of our products through sound warranty requirements, thereby enhancing consumer's willingness to use our products. Our company offers one-year warranty and repair services for electronic components.

■ Warranty Label and Serial Number

Please consult with the agent or the dealer in local.



■ Scope of Warranty

If the functions of this product are affected due to material or manufacturing defects during the warranty period, our company will be responsible for repairing this product or replace this product with the same model.

■ Exclusions From Warranty

Under any of the following circumstances, this product will not be covered by the warranty even though the warranty period has not expired. The consumer must bear all repair or material costs. The relevant charges are set by the maintenance and repair outlet designated by the dealer or local distributor.

1. Unable to prove the warranty period of the product, or exceed the warranty period of the product.
2. The product serial number is inconsistent, or the product serial number is vague, or has been altered or torn up.

3. Damages resulted from the consumer's failure to use the product according to the user guide or manual, as well as damages to the product due to force majeure (natural disasters, floods, fires, earthquakes, lightning strikes, typhoons, pests, etc.), human destruction (scratch, fall, crack, knock, rupture, hit, etc.), human error (loss, liquid intrusion, failure to keep the product in safety, etc.) or other abnormal factors.
4. Scratches or wear and tear on product casing or contactable parts, which do not need to be disassembled, due to normal use.
5. Damage caused by the installation, addition, expansion, modification or repair of parts, which our company does not authorize or recognize, by the customer or third parties.
6. Scope of product replacement for defects in new products:
 - Unable to turn on the power ■ Unable to operate and adjust the buttons
 - Unable to display the screen properly ■ The control function is invalid.New products shall be handled by maintenance if the scope of product replacement is not met.
7. During parts replacement, our company provides products with similar specifications or of better quality. If not agreed in writing by both parties, our company shall own the defective parts after repair and replacement.
8. Damage to the exterior, external casing and decorative components which are not covered by this valid warranty, where free repair service cannot be provided.
9. Products purchased from distribution channels which are not authorized by our company.

10. Damage resulted from consumer's own shipping process.
11. Malfunctions caused by products (equipment) other than this instrument

■ Other Suggestions

Please confirm your product specifications and accessories.

■ Reserved Rights

We will reserve the rights to changing the content of terms, we will post new terms if it has any changes, but we do not inform individual customers.